

22.1.2 CS-Z50VKEW CS-Z71VKEW CS-XZ50VKEW

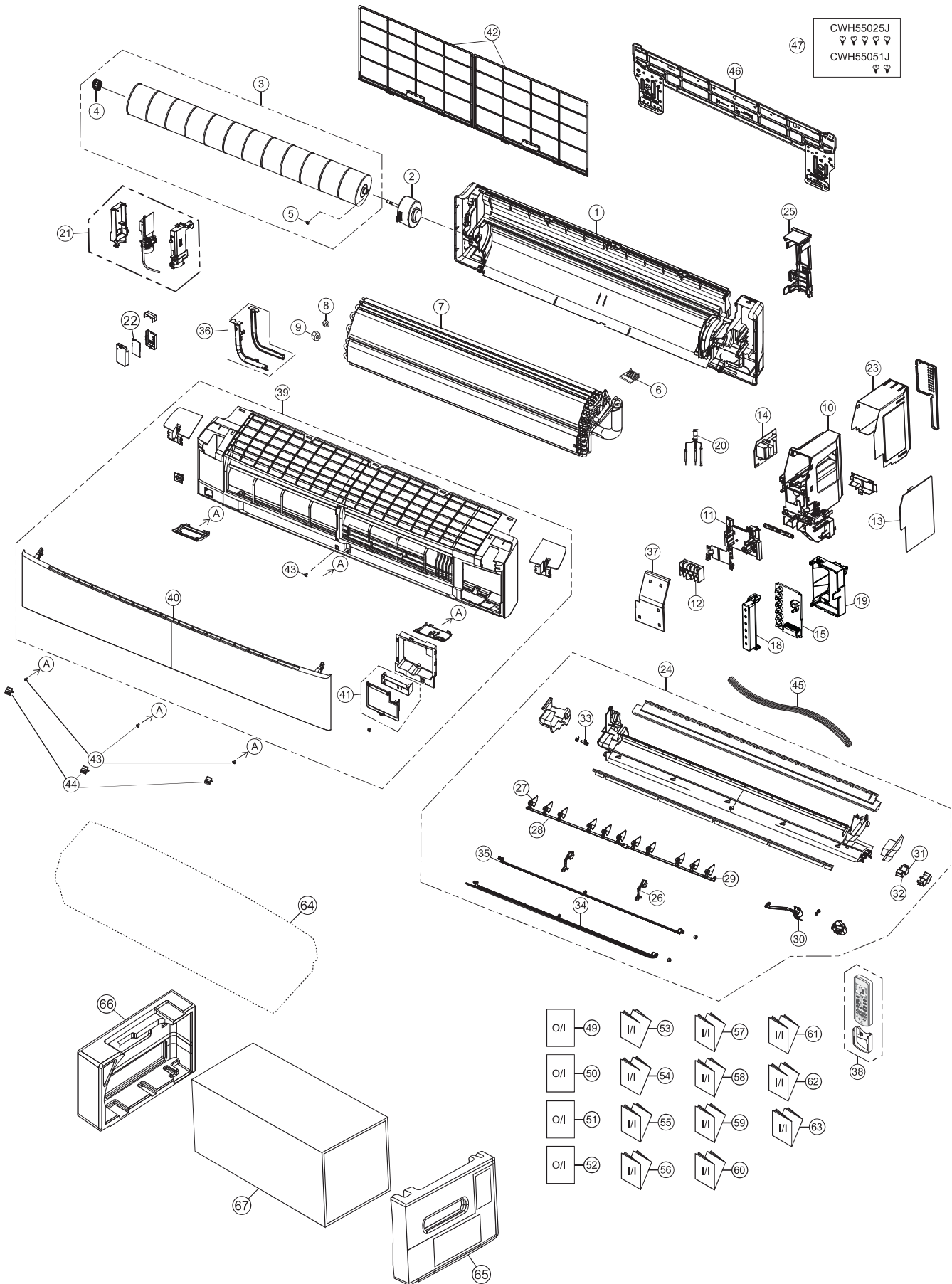

Note
 The above exploded view is for the purpose of parts disassembly and replacement.
 The non-numbered parts are not kept as standard service parts.

SAFETY	REF. NO.	PART NAME & DESCRIPTION	QTY.	CS-Z50VKEW	CS-Z71VKEW	REMARK
	1	CHASSIS COMPLETE	1	ACXD50C01590	←	
⚠	2	FAN MOTOR	1	L6CBYYL0193	L6CBYYL0194	O
	3	CROSS-FLOW FAN COMPLETE	1	CWH02C1136	←	
	4	BEARING ASSY	1	CWH64K1010	←	
	5	SCREW - CROSS-FLOW FAN	1	CWH551146	←	
	6	PARTICULAR PIECE	1	CWD933067B	←	
	7	EVAPORATOR	1	ACXB30C02760	ACXB30C01700	
	8	FLARE NUT (LIQUID)	1	CWT251030	←	
	9	FLARE NUT (GAS)	1	CWT251032	CWT251033	
	10	CONTROL BOARD CASING	1	ACXH10-00720	←	
	11	PARTICULAR PIECE - COVER	1	CWD933138	←	
⚠	12	TERMINAL BOARD COMPLETE	1	ACXA28C05590	←	O
⚠	13	ELECTRONIC CONTROLLER - MAIN	1	ACXA73C50950	ACXA73C50960	O
⚠	14	ELECTRONIC CONTROLLER - SUB	1	ACXA73-28560	←	O
⚠	15	ELECTRONIC CONTROLLER - INDICATOR	1	ACXA73-29790	←	O
	18	INDICATOR HOLDER	1	ACXD93-01960	←	
	19	INDICATOR HOLDER	1	ACXD93-01970	←	
⚠	20	SENSOR COMPLETE	1	CWA50C3226	CWA50C2664	O
⚠	21	GENERATOR COMPLETE	1	ACXH94C00970	←	
⚠	22	ELECTRONIC CONTROLLER - WIFI	1	ACXA73-28520	←	
	23	CONTROL BOARD TOP COVER	1	ACXH13-00430	←	
	24	DISCHARGE GRILLE COMPLETE	1	ACXE20C00490	←	
	25	BACK COVER CHASSIS	1	ACXD93-10180	←	
	26	FULCRUM	2	ACXH62-00080	←	
	27	VERTICAL VANE	11	ACXE24-00400	←	
	28	CONNECTING BAR	1	ACXE26-00190	←	
	29	CONNECTING BAR	1	ACXE26-00200	←	
⚠	30	AIR SWING MOTOR	1	ACXA98K00030	←	O
⚠	31	AIR SWING MOTOR	1	ACXA98-01990	←	O
⚠	32	AIR SWING MOTOR	1	ACXA98-02000	←	O
	33	CAP - DRAIN TRAY	1	CWH521259	←	
	34	HORIZONTAL VANE COMPLETE	1	ACXE24C00550	←	
	35	HORIZONTAL VANE COMPLETE	1	ACXE24C00540	←	
	36	DUCT - COMPLETE	1	ACXD22C00240	←	
	37	CONTROL BOARD COVER - COMPLETE	1	ACXH13C00150	←	
⚠	38	REMOTE CONTROL COMPLETE	1	ACXA75C16210	←	O
	39	FRONT GRILLE COMPLETE	1	ACXE10C09090	ACXE10C09100	O
	40	INTAKE GRILLE COMPLETE	1	ACXE22K00160	←	
	41	GRILLE DOOR COMPLETE	1	ACXE14C00050	←	
	42	AIR FILTER	2	ACXD00-00250	←	O
	43	SCREW - FRONT GRILLE	4	XTT4+16CFJ	←	
	44	CAP - FRONT GRILLE	3	ACXH52-00100	←	
	45	DRAIN HOSE	1	ACXH85-00210	←	
	46	INSTALLATION PLATE	1	CWH361098	←	
	47	BAG COMPLETE - INSTALLATION SCREW	1	CWH82C1705	←	
	49	OPERATING INSTRUCTION	1	ACXF55-22540	←	
	50	OPERATING INSTRUCTION	1	ACXF55-22550	←	
	51	OPERATING INSTRUCTION	1	ACXF55-22700	←	

SAFETY	REF. NO.	PART NAME & DESCRIPTION	QTY.	CS-Z50VKEW	CS-Z71VKEW	REMARK
	52	OPERATING INSTRUCTION	1	ACXF55-22710	←	
	53	INSTALLATION INSTRUCTION	1	ACXF60-34310	←	
	54	INSTALLATION INSTRUCTION	1	ACXF60-34320	←	
	55	INSTALLATION INSTRUCTION	1	ACXF60-34330	←	
	56	INSTALLATION INSTRUCTION	1	ACXF60-34340	←	
	57	INSTALLATION INSTRUCTION	1	ACXF60-34350	←	
	58	INSTALLATION INSTRUCTION	1	ACXF60-34360	←	
	59	INSTALLATION INSTRUCTION	1	ACXF60-34370	←	
	60	INSTALLATION INSTRUCTION	1	ACXF60-34380	←	
	61	INSTALLATION INSTRUCTION	1	ACXF60-34390	←	
	62	INSTALLATION INSTRUCTION	1	ACXF60-34400	←	
	63	INSTALLATION INSTRUCTION	1	ACXF60-34410	←	
	64	BAG	1	ACXG86-00130	←	
	65	SHOCK ABSORBER	1	ACXG70-00840	←	
	66	SHOCK ABSORBER	1	ACXG70-00850	←	
	67	C. C. CASE	1	ACXG50-49010	←	

(NOTE)

- All parts are supplied from PAPAMY, Malaysia (Vendor Code: 00029488).
- “O” marked parts are recommended to be kept in stock.